

*23rd World Gas Conference, Amsterdam 2006*

**FIELD TEST OF HYDROGEN IN THE NATURAL GAS GRID**

***Main author***

Henrik Iskov  
Denmark

***Corresponding author***

J. Jensen  
Denmark

## **ABSTRACT**

How to implement the Hydrogen Society? Transport of hydrogen in the existing natural gas grid may be a shot cut, why this option has been investigated under real conditions.

The purpose of the test was to investigate the possibilities of transport of hydrogen via the existing Danish natural gas grid.

Grid facilities for distribution of hydrogen; test of gas meters, and systems for control, regulation and monitoring of these facilities were developed by DGC together with the gas industry. Steel and plastic pipes from the existing gas distribution grid have been adapted for a standalone "miniature gas grid" constructed according to existing standards and authority regulations by the Greater Copenhagen Natural Gas Company (HNG). Tests were made for a total of 340 operation days.

Leaks were detected upon initialization after hydrogen filling; otherwise at months' interval. Components such as valves and filters were taken apart for investigation after the test period.

The results indicate possibilities for hydrogen transportation via the 19 bar steel distribution grid as well as via the 4 bar plastic distribution grid. The plastic grid requires additional (on going) investigations of the tendency towards changes in melting index and reduced resistance against oxidation after hydrogen exposure. Also, the tendency towards increased rigidity of PEM plastic and reduced rigidity for PE100 plastic needs to be investigated further. The tests showed that all joints, components and fixtures of the gas grid should be checked for leakages at regular intervals. Certain components should be modified in order to be hydrogen tight.

### **Project partners**

DGC, HNG, SGC, Tumab, Norsk Hydro

### **Financial support**

Danish Energy Authority, Hydrogen demonstration program

## **Table of Contents**

1. Abstract
2. Background
3. Partners
4. Test set up
5. Results
6. Conclusions
7. Further action
8. References
9. List of figures

## **BACKGROUND**

Natural gas was introduced in Denmark in the early 1980's. A few years later the grid was finished. That means that the transmission and distribution grid is around 25 years old. Grid pipe materials are steel (70% is X70 and the rest is X52 and X42) down to 4 bar gauge. Below this pressure polymer pipes (mainly PE 80) are selected.

There has been a growing interest over the last years about how to implement the hydrogen society. In this connection the issue of if - and how - hydrogen can be transported via the natural gas grid is very important.

A literature study showed that quite a few theoretical investigations, but only very few practical tests had been carried out. To main studies has been identified: A US project from the late 1970's and a German project from the mid-1980's. The need for up-to-date knowledge on the Danish situation was obvious.

Danish Gas Technology Centre (DGC) has just completed part 1 of a project under the Danish Energy Authority's Hydrogen Programme revealing the possibilities of transport of hydrogen via the existing Danish natural gas grid. The investigation has so far covered the distribution grid. For this purpose, a stand-alone "miniature gas grid" was built.

## **PARTNERS ETC.**

DGC developed the facilities for distribution of hydrogen and test of gas meters together with the gas industry, and systems for control, regulation and monitoring of the miniature gas grid were developed by DGC. The tested steel and plastic pipes from the gas distribution grid have been adapted and buried according to existing standards and authority regulations by HNG, the regional natural gas company. Main supplier of components for the project was Strandmoellen Industrigas A/S, a Danish manufacturer of technical gasses and distributions systems, who is very experienced in hydrogen engineering.

Partners in the project were

- Danish Gas Technology Centre
- HNG (Greater Copenhagen Natural Gas)
- Swedish Gas Technology Centre
- Norsk Hydro

Together with the Danish Energy Authority, these partners financed the project.

## TEST SETUP



Figure 1: The photo shows laying of the test pipes. The two black pipes to the left are 19 bar steel distribution pipes. The other pipes are new and second-hand pipes from the Danish and Swedish gas grid.

Grid facilities for distribution of hydrogen, test of gas meters, and systems for control, regulation and monitoring of these facilities were developed by DGC together with the gas industry.

Steel and plastic pipes from the existing gas distribution grid have been adapted for a stand-alone “miniature gas grid” constructed according to existing standards and authority regulations by the Greater Copenhagen Natural Gas Company (HNG).

In order to investigate age effects, polymer pipes of various ages - up to 20 years old - have been tested.

Schematic diagrams over the test facilities can be seen below:

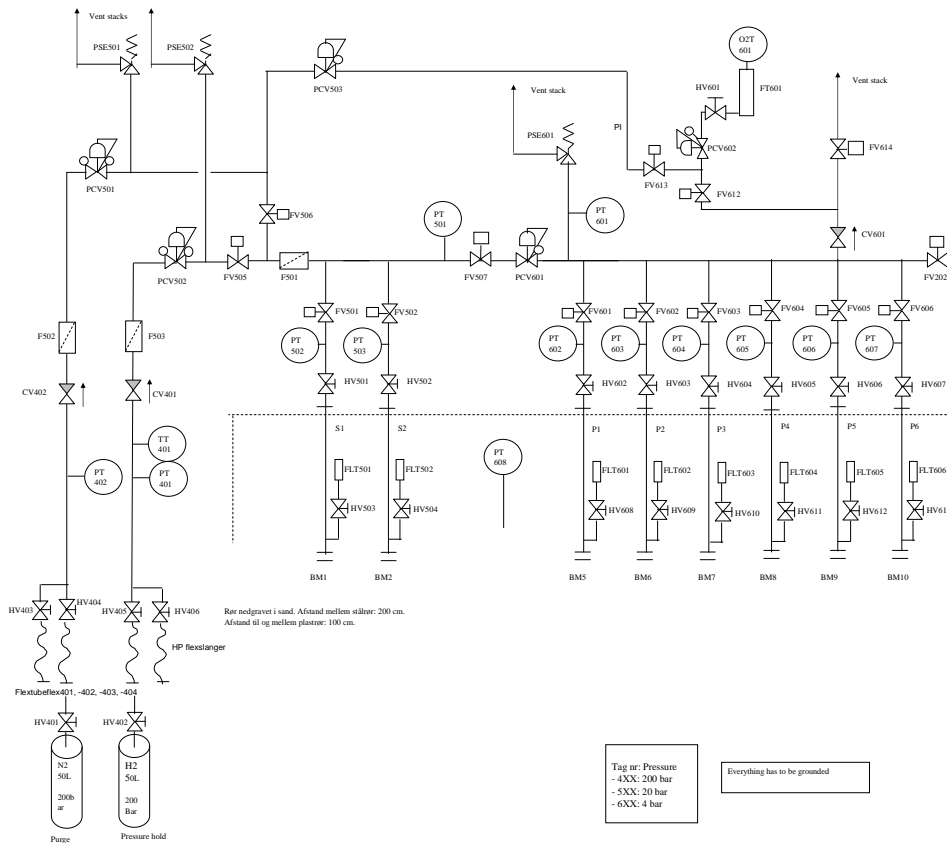

Figure 2: The scheme shows the test rig for testing steel and polymer pipes. All pipes are kept within the normal operational pressure range. 4 bar for polymer and 19 bar for steel distribution.

## Pipes

All pipes were operated at static pressures and no flow. No dynamic loads, i.e. pressure variations simulating line pack, have been incorporated. Pipe polymer material was PE80 and PE100 and the steel pipes were X42. Continuous monitoring of pressures was used to discover leaks. Measuring of oxygen contents detected if the levels reached a critical value.

## Gas Flowmeters

Test of flowmeters necessitates flow generation by compressors. As a part of the test included testing for leaks in the flowmeters, it was necessary to use extremely leak-proof hydrogen compressors. It turned out to be very difficult to obtain such compressors or more precisely hydrogen blowers, as nearly no pressure gain was needed, only flow. Finally, one manufacturer was identified.

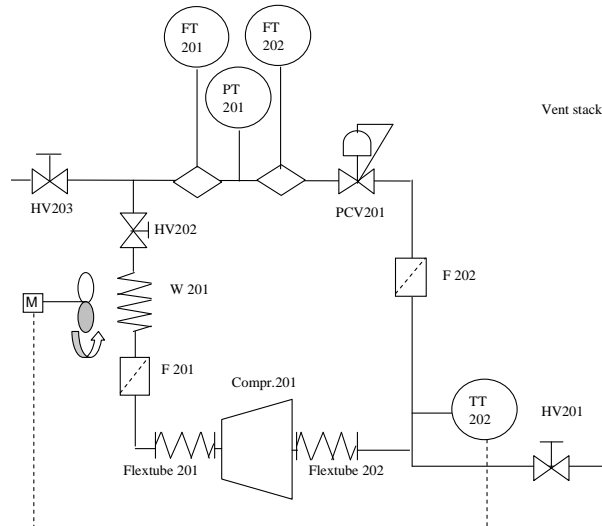

Figure 3: The diagram above shows the test cycle for the two industrial flowmeters for 4 bar pressure level.



Figure 4: The actual construction of the test cycle for the industrial gas flowmeters. The compressor is situated in the grey box at the left bottom of the picture.

The two industrial flowmeters consisted of one rotameter type and one turbine type. Another flowmeter test cycle for household flowmeters of the bellow type was also included in the test operating at around 20 mBar.

Tests were made during almost the entire year 2003; resulting in a total of approx. 340 operation days. Generally, there were only slight operational problems.

## RESULTS

Leaks were detected upon start-up after hydrogen filling; otherwise only at months' interval. However, a slight leakage from one of the gas meters was detected throughout the entire test period.

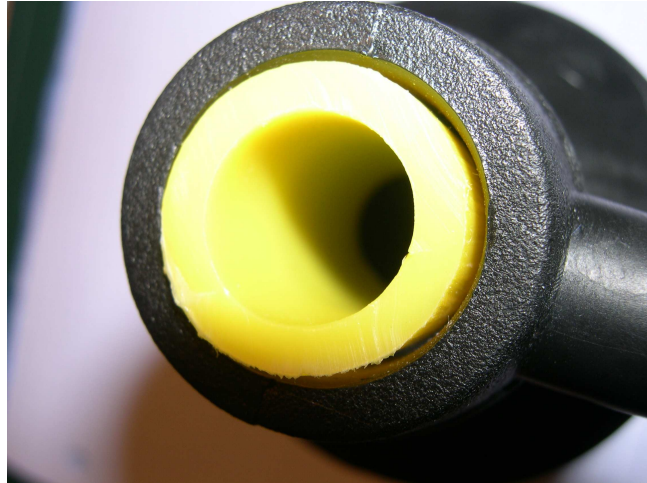

Figure 5: The photo shows a plastic transition joint frequently used in the Danish gas grid. During the tests, this piece connects the supply pipes with the test pipes. At start-up, more than half of these pieces leaked hydrogen and had to be replaced; the reason being a too large clearance between connecting pipe and transition piece.

### **Steel distribution pipes**

Analyses of test data and subsequent material analyses showed that:

- 19 bar steel distribution pipes (x42) were tight through the entire test period, apart from a few times when a threaded joint or a valve became leaky.
- The steel material and welds in this material were completely unaffected by the hydrogen exposure.
- The tensile strength was unchanged, for basic material as well as for welding zones.

### **Plastic distribution pipes**

Similar analyses of test data and subsequent material analyses showed that:

- 4 bar plastic (PE) distribution pipes have been leaking at a constant leak rate throughout the entire test period, corresponding to a loss of 1 bar per year. The calculated permeability of hydrogen through the pipe wall amounts to approx. 20% of the measured leak.
- Practical welding tests have proven an unchanged weldability.
- The melting index for three out of four hydrogen exposed PE80 pipes dropped by 5-10%. This could indicate incipient changes to the material. No changes were found in the PE100 samples (tube number 5 and 6 at Figure 6) after the hydrogen exposure.
- OIT (oxygen induction) tests showed that the efficiency of the added antioxidant was reduced and that a few years of continued hydrogen exposure could reduce weldability to an unacceptable level for high-strength PE100 pipes. See Figure 7.
- The tensile strength is unchanged, for basic material as well as for welding zones.
- Infrared spectroscopy has shown that the basic material did not change its chemical composition.

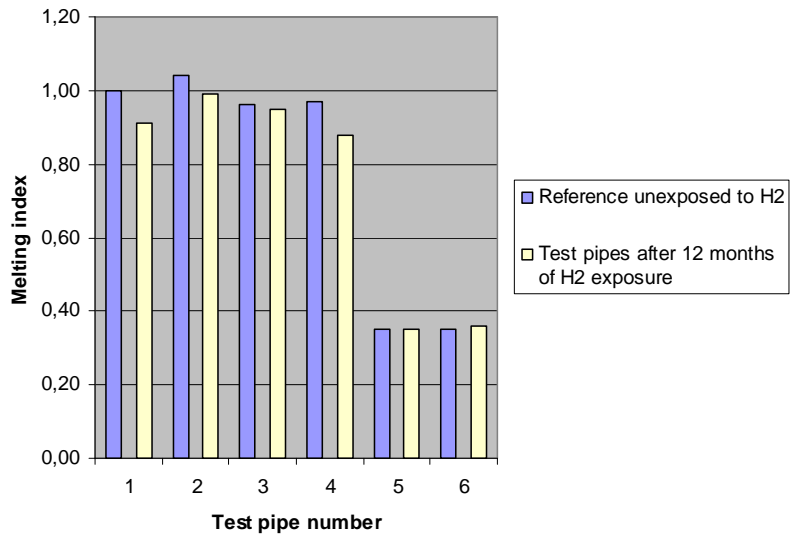

Figure 6: Melting index test according to ISO 1133.

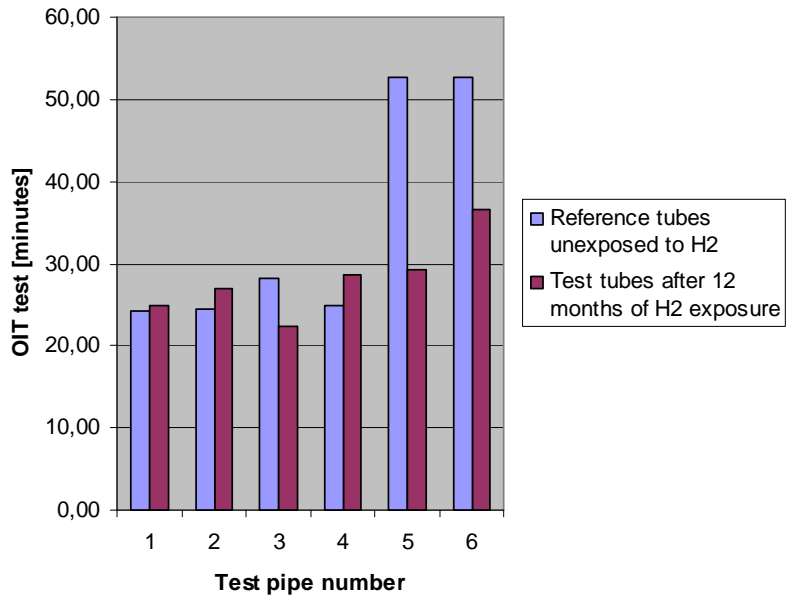

Figure 7: Oxygen induction test according to DS 2131.

## Gas flowmeters

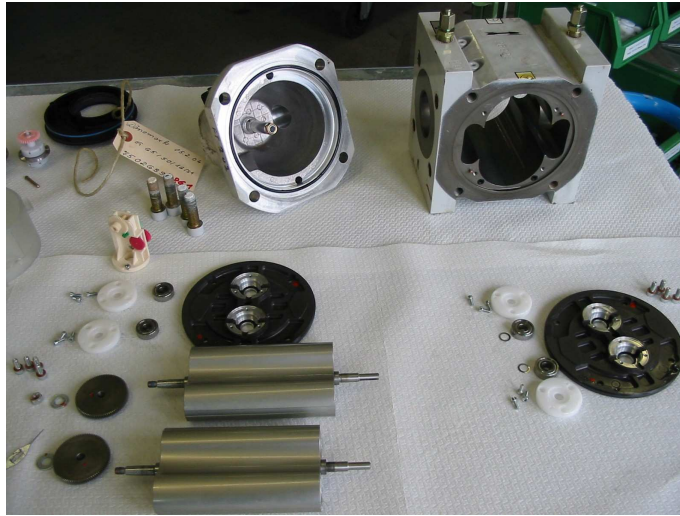

Figure 8: Rotational type industrial gas flowmeter dismantled before inspection for damages at the manufacturer (Elster)



Figure 9: Turbine type gas flowmeter dismantled before inspection and recalibration at the manufacturer (Elster)

The tested gas flowmeters are widely used in the Danish gas grid. One flowmeter of the turbine type and one flowmeter of the rotational type.

Industrial gas meters and the domestic gas meter were not damaged by the test operation.

- Recalibration at the manufacturer's test bench has shown that all meters complied with specifications.
- Detailed investigations of sensitive components such as rubber gaskets etc. show no signs of abnormal wear or incipient decomposition.
- During the test period a constant minor leak from the turbine gas meter was detected. The above detailed investigations showed no defects in the leaking components. I.e. a change of design is necessary when converting to hydrogen.
- The oil in the rotary gas meter was analyzed after 12 months of exposure to hydrogen. After 12 months the oil still complied fully with the specification. No indication of deterioration was detected.

## Other components

Other components such as valves and filters were taken apart for investigation after the test period. Nothing seemed to indicate damages caused by hydrogen exposure.

## CONCLUSION

The overall conclusion is that test results indicate possibilities for hydrogen transport via the 19 bar steel distribution grid as well as via the 4 bar plastic distribution grid.

The plastic grid requires additional investigations of the tendency towards changes in melting index and reduced resistance against oxidation after hydrogen exposure. Also, the tendency towards increased rigidity of PEM plastic and reduced rigidity for PE100 plastic needs to be investigated further. The project showed that all joints, components and fixtures of the gas grid should be checked for leakages at regular intervals. Certain components should be modified in order to be hydrogen tight.

The results of the investigation are extensively reported in a project report (in Danish) /2/ that can be ordered from Danish Gas Technology Centre or downloaded from [www.dgc.dk](http://www.dgc.dk).

## FURTHER ACTION

The results are used as basis for a three-year continuation of the project. The objective is to determine whether the tendency of incipient changes to the material of plastic pipes will continue after prolonged hydrogen exposure.

The operational conditions will be slightly different from the part 1 project. The polymer pipes will be exposed to a continuous flow of hydrogen which will be renewed slowly to ensure that the tubes always are exposed to "fresh" hydrogen.

The project includes testing of steel pipes from the Danish gas transmission grid (x52 and/or X70). This may include dynamic testing (pressure variations in order to simulate line packing) - as fatigue fracture growth is expected known to accelerate in the presence of hydrogen.

The test phase of the project is scheduled to begin in the first half of 2006.

## REFERENCES

1. Andersen, Paw, Celia Juhl, Lars Bo Pedersen, Asger N. Myken, Henrik Iskov: Hydrogen as an energy carrier. (In Danish with English summary only). Dansk Gasteknisk Center a/s. 1999. ISBN 87-7795-172-7.
2. Iskov, Henrik: The suitability of the gas grid for distribution of pure hydrogen. (In Danish with English summary only). Dansk Gasteknisk Center a/s. 2004. ISBN 87-7795-253-7.

## LIST OF FIGURES

Figure 1: The photo shows laying of the test pipes. The two black pipes to the left are 19 bar steel distribution pipes. The other pipes are new and second-hand pipes from the Danish and Swedish gas grid.

Figure 2: The scheme shows the test rig for testing steel and polymer pipes. All pipes are kept within the normal operational pressure range. 4 bar for polymer and 19 bar for steel distribution.

Figure 3: The diagram above shows the test cycle for the two industrial flowmeters for 4 bar pressure level.

Figure 4: The practical built up of the test cycle for the industrial gas flowmeters. The compressor is situated in the grey box at the left bottom of the picture.

Figure 5: The photo shows a plastic transition joint frequently used in the Danish gas grid. During the tests, this piece connects the supply pipes with the test pipes. At start-up more than half of these pieces leaked hydrogen and had to be replaced; the reason being a too large clearance between connecting pipe and transition piece.

Figure 6: Melting index test according to ISO 1133.

Figure 7: Oxygen induction test according to DS 2131.

Figure 8: Rotational type industrial gas flowmeter dismantled before inspection for damages at the manufacturer (Elster)

Figure 9: Turbine type gas flowmeter dismantled before inspection and recalibration at the manufacturer (Elster)

Pas photo of Henrik Iskov (main author)

